

# Bonito Bebé

## TOSCANA DRESSER

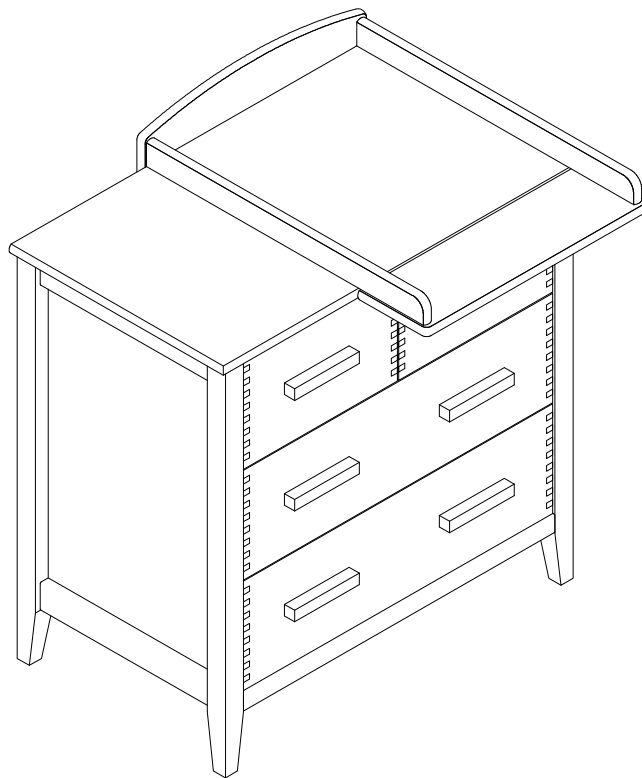

**IMPORTANT - RETAIN FOR FUTURE REFERENCE. READ CAREFULLY.**

**WARNING : DO NOT LEAVE YOUR CHILD UNATTENDED -  
YOUR CHILD'S SAFETY IS YOUR RESPONSIBILITY**

**[www.glasgowpramcentre.co.uk](http://www.glasgowpramcentre.co.uk)**

# THESE INSTRUCTIONS ARE IMPORTANT - PLEASE READ CAREFULLY AND RETAIN FOR FUTURE REFERENCE

We strongly suggest you spent a short time reading through this leaflet and then follow the simple step by step guide to assembly.

**WARNING : Do not leave your child unattended.**

The correct use and maintenance of your changer will ensure it gives long and trouble free use. Remember the safety of the child is your responsibility.

## MATERIAL

Your changer is made in solid ash and ash veneer. Ash is a totally natural material therefore no two pieces are ever identical in pattern or colour. As ash furniture gets older its colour may change due to being exposed to light and air, so any new pieces may look a shade different to those you already have. Don't be concerned about this, as the colour difference will diminish over a small period of time.

Every piece has its unique appearance.

To keep the natural aspect, the surfaces were coated with a protective lacquer. The beauty of your furniture can be maintained, cleaning it with a soft cloth. Occasionally a damp cloth, followed by a soft dry one, may be used. All furniture can be damaged by knocks and scrapes - if you dent the surface or break the seal of the lacquer, apply some solid wax to exclude the atmospheric moisture.

## ASSEMBLY

Before starting the assembly, please read through these instructions. Then carefully unpack your changer and check that you have a complete set of parts against the list.

We recommend that you assemble your changer on a clean, flat surface, making sure there are no sharp objects present that may mark or damage the panels.

When gluing, use small amount of glue on the dowels and not in the dowel holes. Wipe away any excess immediately with a clean damp cloth

The doors can be adjusted both forward and backwards, side to side and up and down by using the mounting screw, the adjusting screw or by moving the hinge plate. Re-tighten when the doors is in the right position

## CAUTION

There are many small components used in the construction of this changer. These items should be kept out of reach of young children whilst assembling the unit.

## INSTRUCTIONS FOR SAFE USE

- Place your changer on a stable surface
- Regularly check all the fittings to make sure they are tight and that the changer is not damaged. Take care that no screws are loose, because a child could trap parts of the body or clothing, which could pose a risk of strangulation.
- Do not place your changer in the close proximity of an open fire and the sources of heat, such as radiators, electric or gas fires.
  - We recommend a changing pad *no more than 3cm in thickness*.

## Glasgow Pram Centre

25 – 29 McFarlane Street  
Glasgow  
G4 0TL









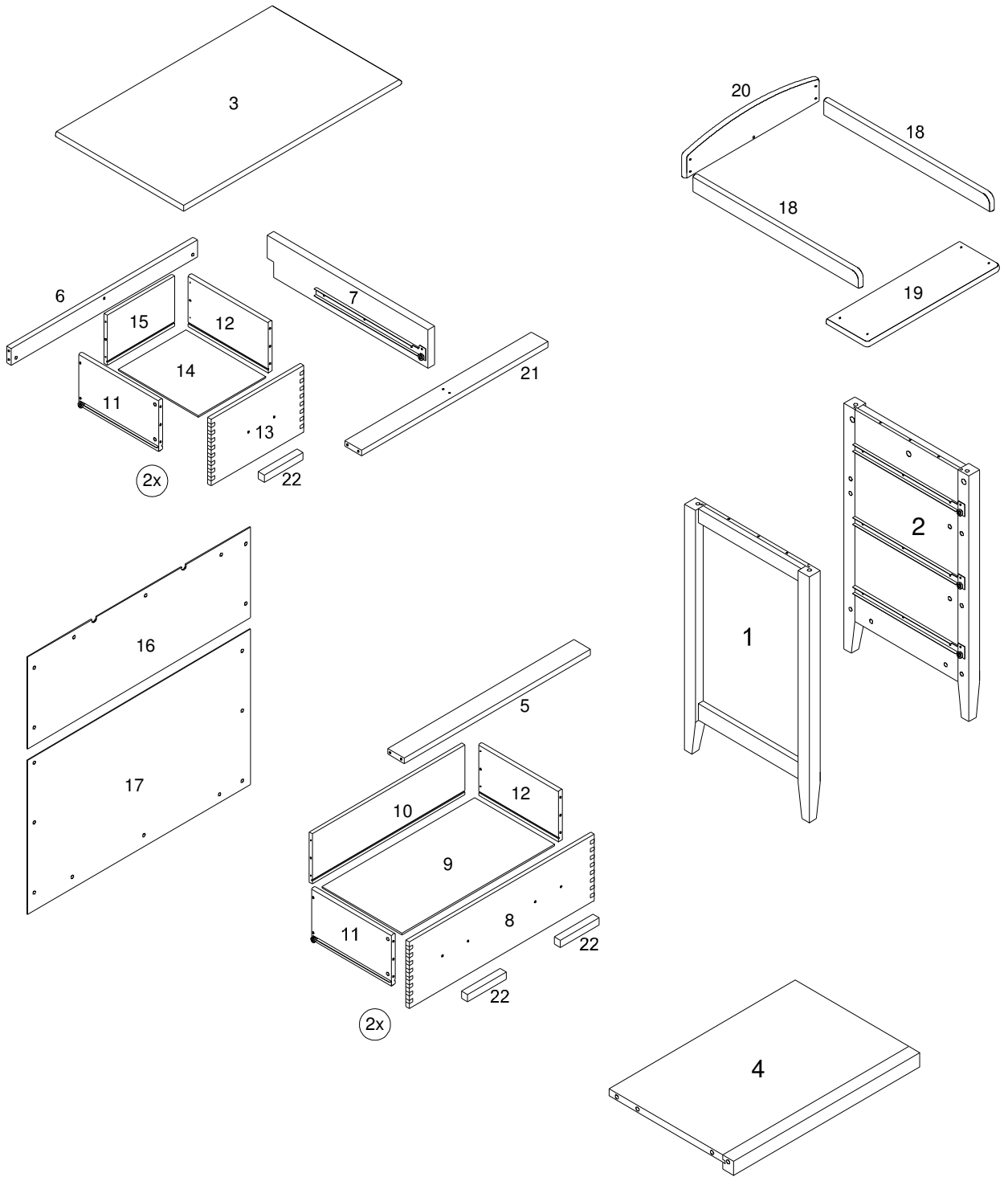

p - 0141 552 3998

f - 0141 552 4423

e - [sales@glasgowpramcentre.co.uk](mailto:sales@glasgowpramcentre.co.uk)

[www.glasgowpramcentre.co.uk](http://www.glasgowpramcentre.co.uk)



A	B	C	D	E	F	G	H	I	J	K
										
x 30	x 32	x 32	3.5x25 x 19	x 12	x 9	3.5x12 x 22	x 1	x 1	x 5	x 3

1.

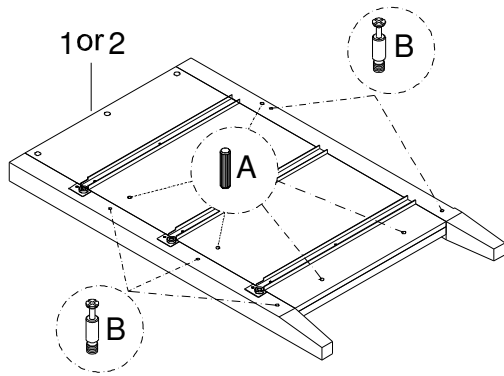

2.

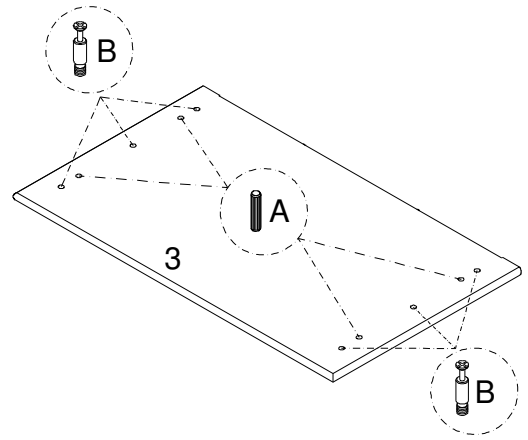

3.

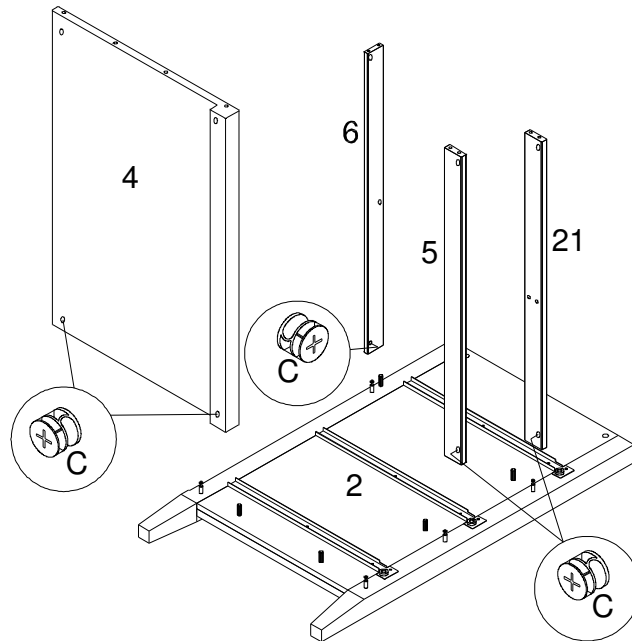

4.

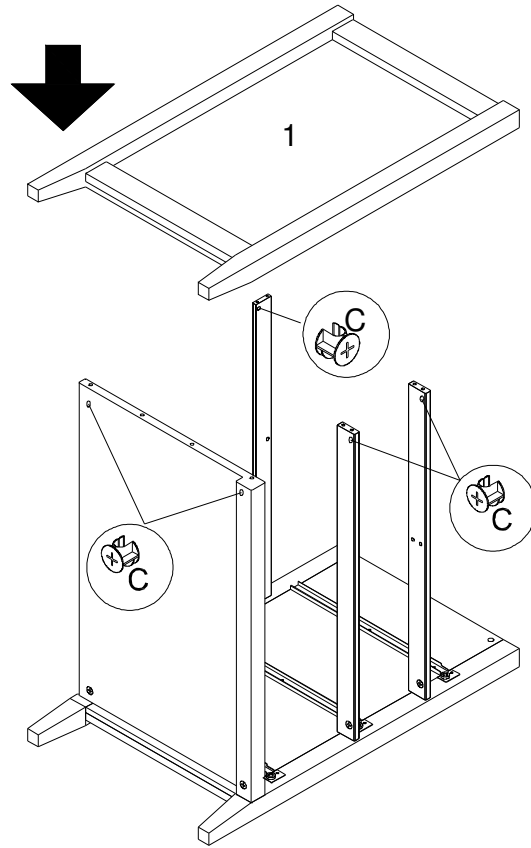

5.

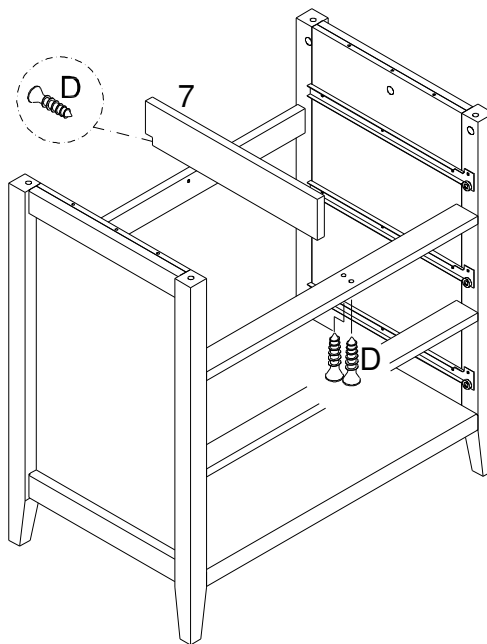

6.

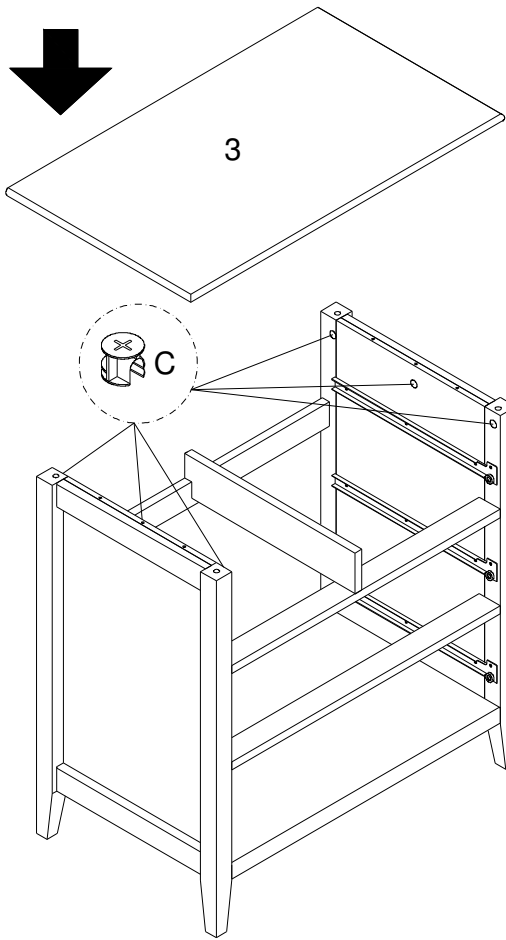

7.

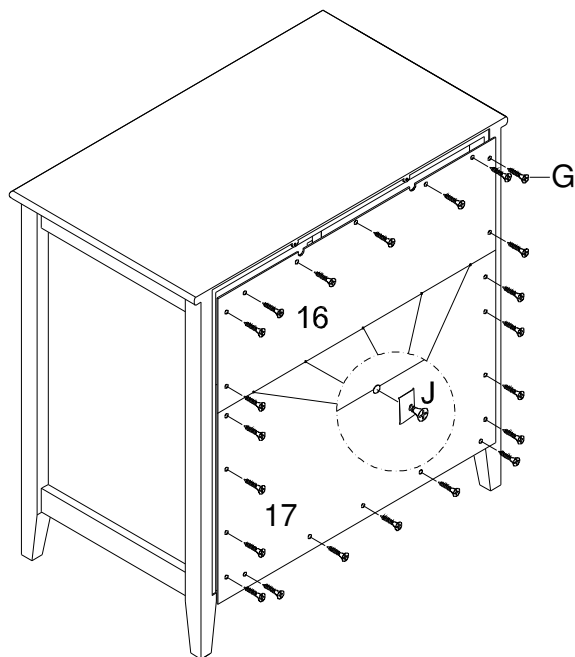

8.

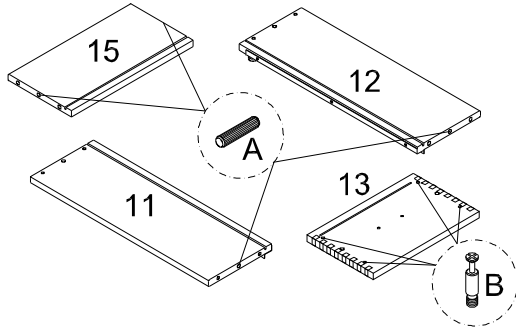

9.

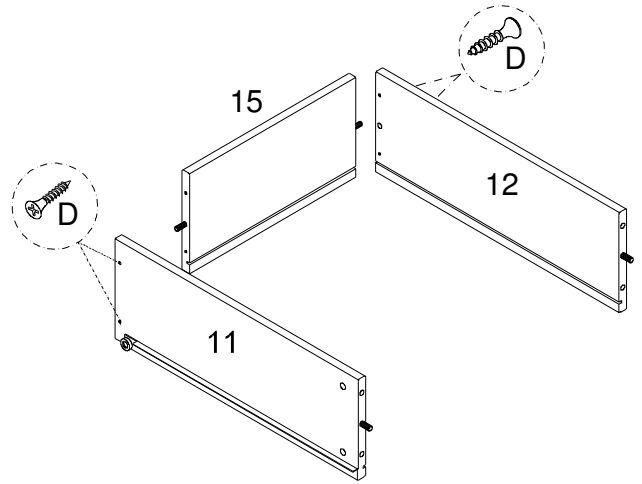

10.

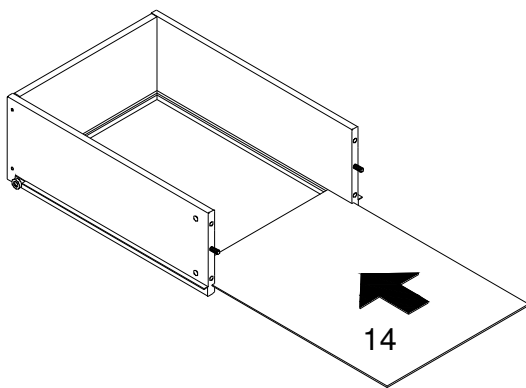

11.

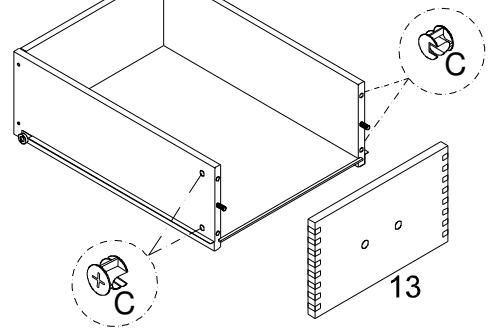

12.

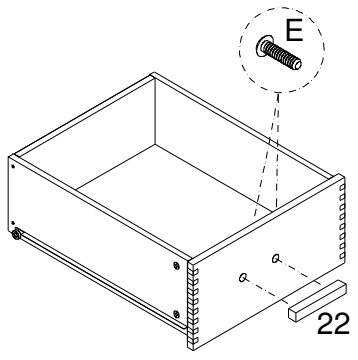

13.

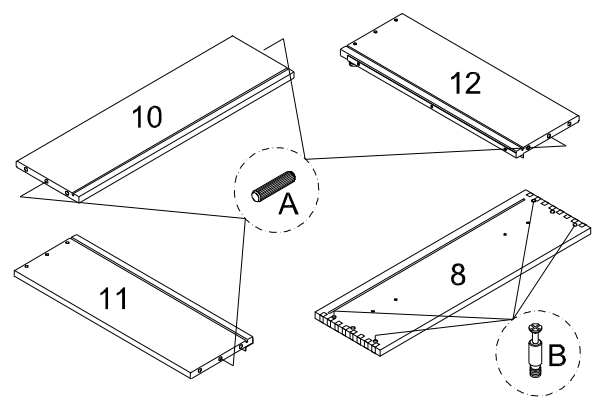

14.

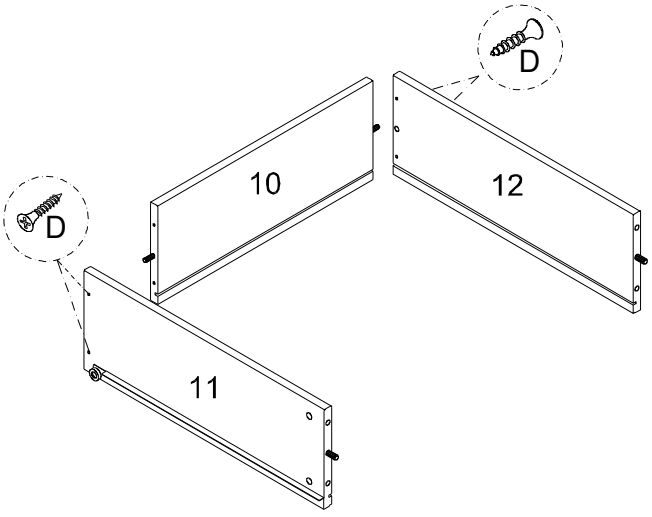

15.

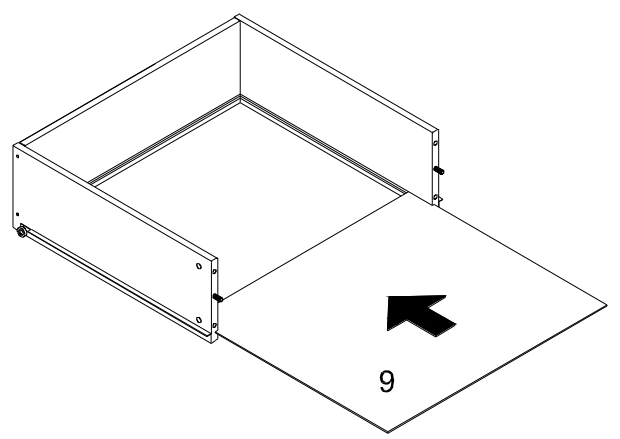

16.

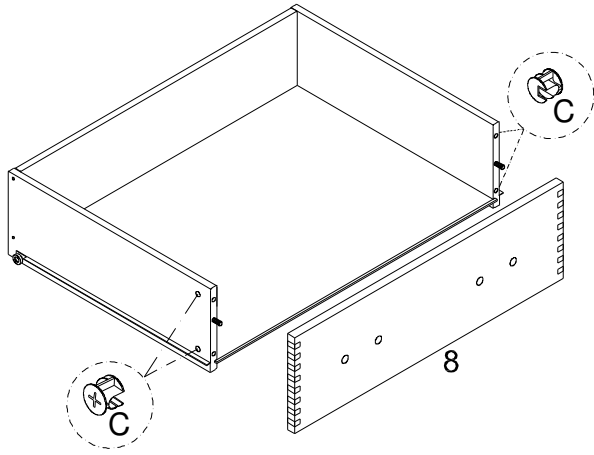

17.

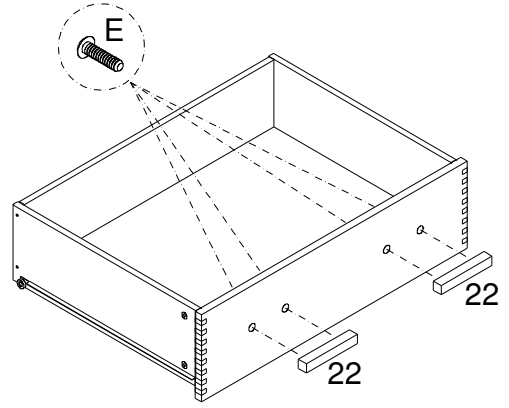

18.

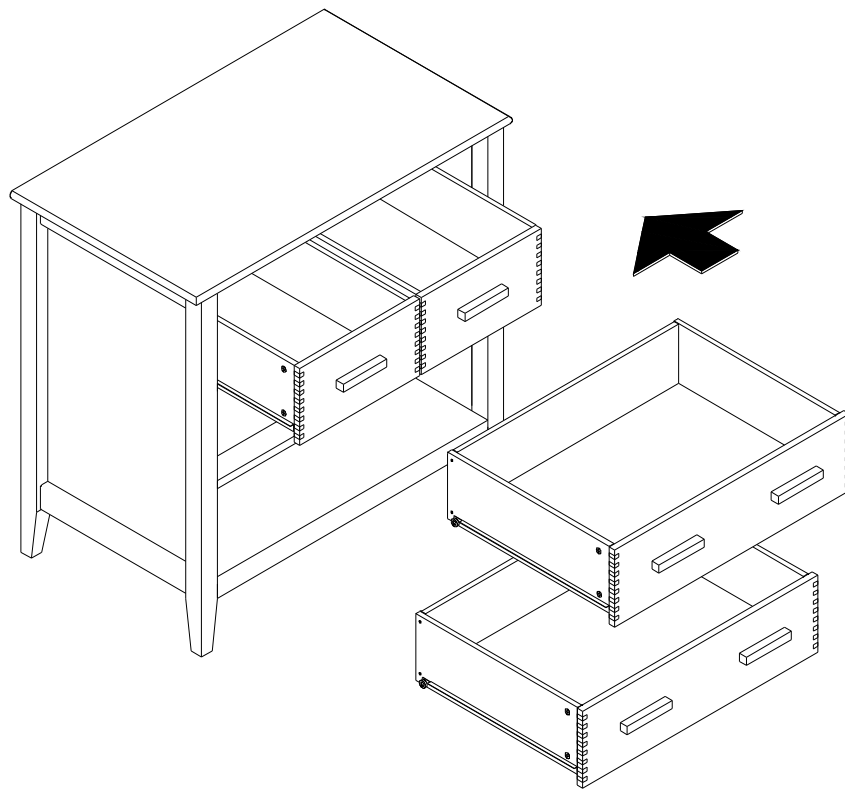

19.

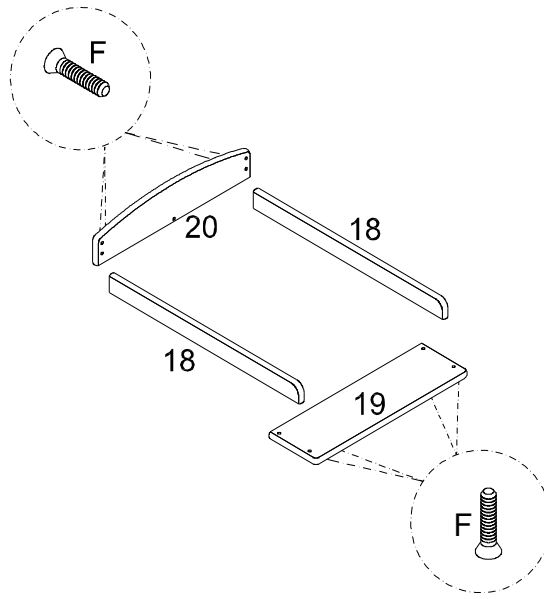

20.

